

SYSTEM JAKOŚCI
ISO 9001
ZGODNY Z NORMĄ



OPERATION MANUAL
CENTRIFUGAL IMPELLER PUMPS
TYPE **NHV**

**The present manual
should be given to the final operator
and be present in the place
where the pump is mounted**

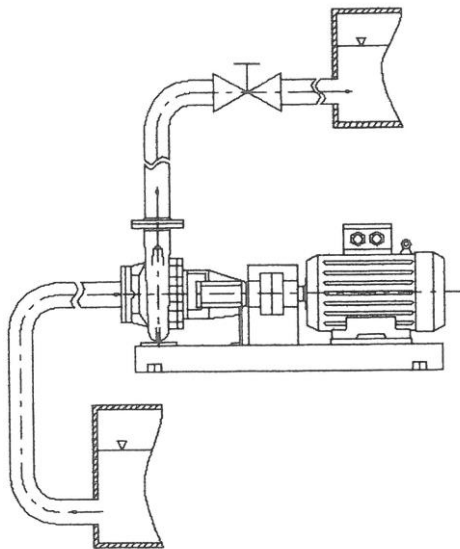

Fig.1 Lay-out of NHV pump unit operating with suction

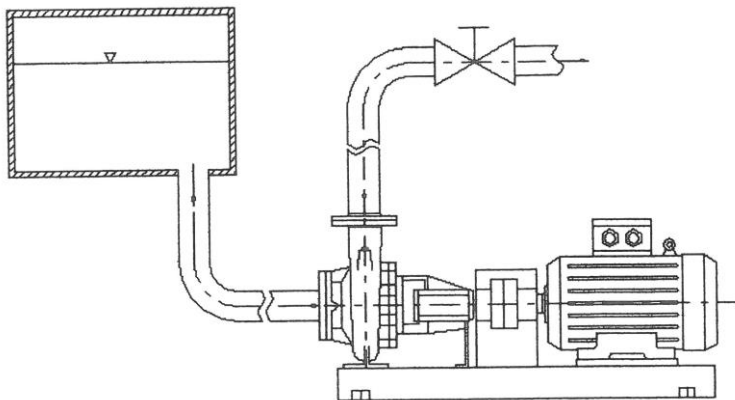

Fig.2 Lay-out of NHV pump unit operating with inflow

1. GENERAL INFORMATION.

Hydro-Vacuum pumps are manufactured very carefully, with manufacturing process controlled on each stage, according to ISO requirements. Before leaving our factory, every pump is thoroughly inspected and tested to assure its quality and performance. Proper installation, service and maintenance would ensure proper pump operation.

The present manual contains important instruction regarding safe, proper and economical exploitation of the pump. We suggest to read this manual carefully, with understanding, because acquaintance and compliance of this instructions will ensure a reliable and long life operation.

This manual does not contain the local requirements and regulations, so the responsibility for fulfillment of local rules belongs to the user.

The pump assembly shall not be exploited against its destination regarding physical and chemical properties of the handled medium, i.e. efficiency, pressure, temperature, density, aggressiveness, abrasiveness, as well as operating parameters specified in the Technical Specification of the pump or the contract documentation.

The data plate of the pump and of the motor specifies the type-size, the mean operating parameters and the serial number (identification number, which should be marked in correspondence, orders, especially in spare part orders). Compare these data with the data in your order and/or contract documentation.

All Hydro-Vacuum products are guaranteed according to the "Warranty Certificate" Hydro-Vacuum is not liable for defects arising out of following causes:

- the pump has been damaged during transportation, by badly storage or incorrect installation;
- the pump is installed or operated against instruction given in this manual;
- the pump was used for handling liquid other than specified in its Technical Specification, i.e. aggressiveness of handled liquid exceeds corrosion resistance of materials used in the pump;
- the pump was disassembled in the warranty period without manufacturer's permission.

CAUTION!

The manufacturer is not liable for any damage resulting from non-observance of warranty terms and conditions by the pump operator.

In case of damage or malfunction please contact the nearest authorized service or representative of Hydro-Vacuum

1.1. Symbols used in the manual



Safety guidelines and instructions; failure to comply may affect operation safety



Electrical safety guidelines and instructions; failure to comply may affect operation safety.



Hazards which may affect operation safety



Guidelines and instructions for use in explosive hazardous areas

1.2. Personnel qualifications

Maintenance, inspection, service and assembly personnel must have verified qualifications.

1.3. Risks of non-observance of safety requirements

Non-observance of safety requirements may result in the following risks for:

- personnel, related to electrical or mechanical causes,
- pump unit,
- environment, resulting from leakage of hazardous substances.

1.4. Unauthorized modification and fabrication of spare parts

Modifications of pump unit or installation is permitted if authorized by the manufacturer. For safety reasons, use genuine spare parts and equipment recommended by the manufacturer. Manufacturer is not liable for damages resulting from use of other spare parts.

1.5. Unacceptable operation

Reliability of pump unit operation is guaranteed when it is used as intended. In no case it is accepted to exceed limit values detailed in the pump unit specification.

2. TRANSPORTATION AND STORAGE.

On the receipt of the pump, check it for any damages resulted from transportation. Any damage should be immediately submitted to the transport agent.

If the pump will be installed in a later period, it should be stored in a dry room and protected against mechanical damages and atmospherically influence (humidity, freeze, etc.)

In case of long-lasting storage, make sure the impeller rotates before initial start-up. Manually rotate motor shaft after removing the fan cover and impeller cover.

CAUTION!

Lockout of an impeller may be eliminated by filling pump unit with hot water, and if it does not help, remove the water and contact the nearest service station.



It is not permitted to use for pump unblocking by force on behalf of such special tools like chain spanner, because it may damage the rotating set and packing!

During transportation should the pump set be protected against mechanical damages and atmospherically influence. Pump sets of a weight more than 70 kg have in the foundation plate holes for hanging up during transportation (see fig. 3).

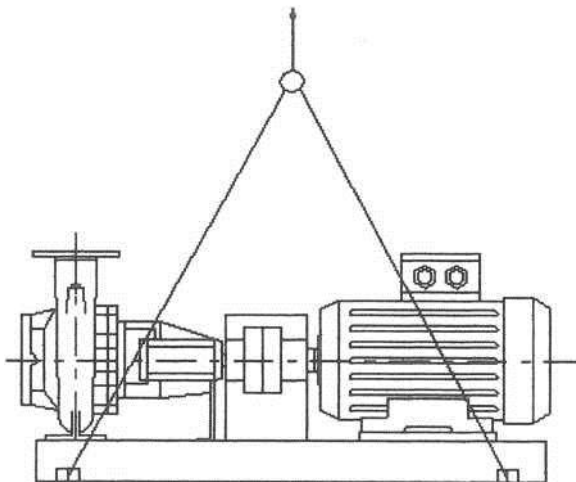

Fig.3. Hanging up of the pump unit assembly

3. PUMPING SET DESCRIPTION.

Before installation of the pump assembly, it is required that the operator checks and compares the data specified on the data plate with the data in the order (or contract documentation). The operator shall acknowledge himself carefully with the present Operators Manual and Technical Data.

3.1. Pump

Example of pump designation NHV.80-200/1.2.1100.5

NHV	- pump type
80	- type size (discharge port diameter)
200/1	- type dimension (impeller diameter characteristics)
2	- material options
1100	- design options
5	- delivery completeness

CAUTION!

Before installation and first starting up, the operator should indispensably acknowledge with the Technical Specification of the delivered pump set.

NHV type pumps are single stage, horizontal, impeller centrifugal pumps. Within a unit, pump is coupled with motor with a flexible coupling and positioned on the common base plate. Pump impeller is a closed type with a single sided inlet. Pump shaft is supported by rolling bearings. Pump shaft sealing: rope or end-face mechanical seal depending on the version.

3.2. The motor

Pumps are driven by electric motors with lugs, supplied with 50 Hz current and 1450 Vmin and 2900 $\frac{1}{\text{min}}$ speed, and different versions depending on the intended use of the pump unit e.g.: - marine version, Ex version and 60 Hz motors.

CAUTION!

Other methods of power transmission are permissible, provided that the only load of the pump shaft end is the twisting moment.

CAUTION!

Electrical parameters, dimensions and weight of the motor are specified in the Technical Specification of motor. These data are included in the documentation delivered with the pump.



The electric installation should be performed by an authorised electrician and should conform to local requirements.

Dimensions, weight and operation parameters of the pump unit are specified in the data sheet.

3.3. Pump unit setup

When installing pump unit on the concrete foundation its recommended height is min, 10 cm when using anchoring bolts.

CAUTION!

Dimensions and spacing of anchoring bolts are detailed in pump Specification.

Base plate shall be horizontal. Pump unit shall be positioned horizontally. It is recommended that the base plate is positioned on a cement mortar. After the device is fastened to the base plate with anchor bolts and the hydraulic connections are completed, check if the pump and motor are in a correct position in relation to each other and the rotating unit rotates freely. Check coupling.

The position of two parts of flexible coupling shall be as per Fig. 4 and Fig. 4a.

Permissible gap measured at the coupling circumference for type E, type A and type I couplings may not exceed values specified in Table 1

Table 1

Type clutch	Dimension [mm]	
	a	b
E	2+0,5	0,2
A	5+0,5	0,3
I	3,8±0,5	0,2

The concentricity of pump and motor shaft can be checked with a rule and a feeler gauge. Dimension “b” can be corrected with a washer under the pump or motor mounts. After the setting is completed, install coupling guard and other safety guards.



Do not run the pump unit without coupling guard and safety guards

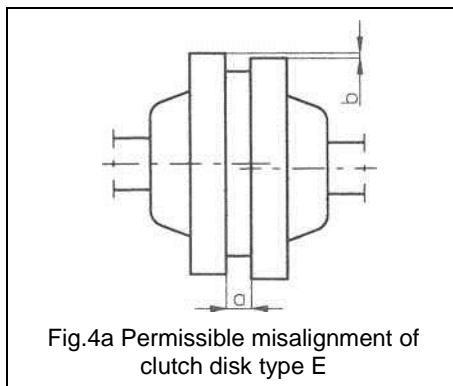

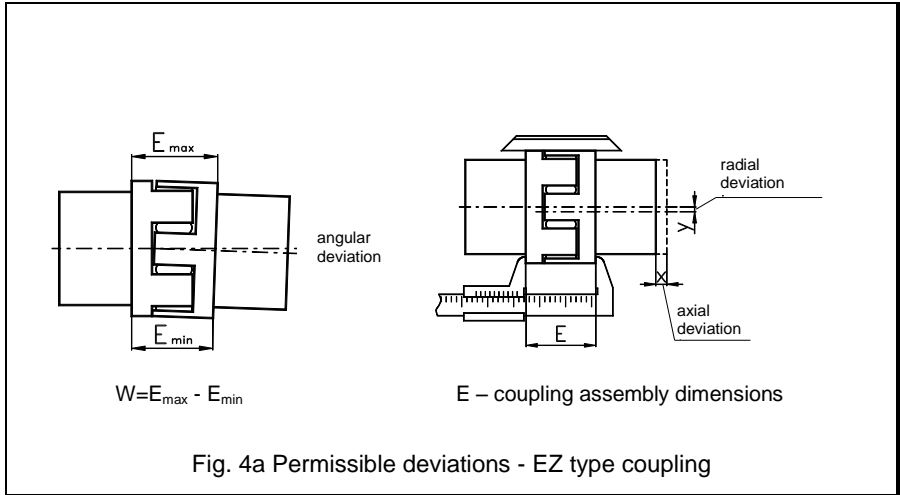

Table 2

Type clutch	Dimensions			
	E [mm]	x [mm]	y [mm]	W[mm]
EZ 1	32	1,0	0,2	0,8
EZ3	40	1,0	0,2	0,8
EZ 7	49	1,5	0,3	1,0
EZ 9	62	1,5	0,3	1,5
EZ 10	78	1,5	0,4	1,5

x, y, W - maximum deviation values for couplings

CAUTION!

Correct shaft alignment ensures long service life.

4. INSTALLATION.

4.1. Safety requirements for installation and inspection works

User must make sure that all the installation and inspection works are made by an authorized and qualified personnel. Make sure the personnel understood the Operating Manual. Works may be carried out when the unit is not operative. Pump units pumping hazardous substances must be subjected to substance neutralization. When operations are finished, all protective devices must be reinstalled and restarted before the pump unit is restarted. Observe the required procedure.

4.2. Hydraulic system

The pump may operate with suction (Fig. 1) or with inflow (Fig. 2).

- When pumping from the tank located below the pump unit, suction line must be positioned in a way, that each subsequent point of the pipe positioned near the pump has an ascending tendency. If it is required to bend a suction line to the top, it is required to install vents for removing gas from the suction line in its top point. Degassing procedure must be carried out after the pump unit is deactivated. Pump unit must be equipped with a non-return valve installed in a strainer or at the inflow of a pump unit. Without the valve, degassing is not possible.



Maintain caution when degassing to avoid contact with liquids and gases.

- Directly in front of a pump unit inlet, it is required to install straight cable section, slowing the liquid stream at the distance of 5-times the suction line diameter.
- Protect pump unit against dry operation. Before each start-up verify the pump is filled with liquid. Fill up the pump before use.
- For both pump units operating with suction and inflow it is required to install cut-off valves on suction and pressure line in front of a pump.
- Maintain correct suction head resulting from NPHS value for specific pump unit.
- Remember that the altitude and temperature reduce the suction head.

Altitude (m)	Drop of suction lift (m)
0	0
500	0,60
1000	1,15
1500	1,70
2000	2,20
2500	2,65
3000	3,20

Water temp. °C	Drop of suction lift (m)
20	0,20
30	0,40
40	0,70
50	1,20
60	1,90
70	3,10
80	4,70
90	7,10
100	10,30



The above table refers to handling water. In case of other liquids, especially with high vapour pressure, check if your pump should not be installed with inflow.

- Before starting installation should the pipeline be thoroughly cleaned from dust, welding scale and other dirt and foreign matter.



Any foreign matter getting into the pump will cause its breakdown. To avoid this, install an adequate filter and/or separator in the suction pipe.

- The pipeline should be hanged up or supported in a way avoiding acting forces on the pump body, forces and moments within the limits specified in Table 5.
- The horizontal part of the suction pipe should be as short as possible. Unless necessary, avoid elements introducing hydraulic resistance (e.g. curves, contractions, valves).
- The suction pipe should be equipped with a check valve with a strainer.

CAUTION!

During installation make sure, that the applied washers do not obstruct the clearance of the suction pipe.

CAUTION!

The summary clearance of the strainer openings should be at least three times greater than the clearance of the suction pipe.

- Diameters of the suction and pressure pipelines shall not be smaller than the diameter of the pump stub (these data are included in the Technical Specification of the pump).



If the above principles are not observed, the flow resistance will increase and the pump efficiency would be lower than given in the manual.

CAUTION!

The following terms and conditions apply. The warranty does not cover any damage resulting from non-observance of the warranty terms and conditions. Pump unit may not be used to pump products exceeding corrosion resistance parameters of materials used for its construction.

Permissible forces and moments exerted on ports of NHV type pump as per PN-EN-ISO -5199

Pump type	Port location	DN mm	Family no.	Material feature	Power				Moment			
					FY	FZ	FX	ΣFb	MY	MZ	MX	ΣMb
NHV	pump port in vertical "z" axis	32	1A	cast iron, bronze	297	367	315	577	262	297	385	560
			1B	cast steel	595	735	630	1155	525	595	770	1120
		40	1A	cast iron, bronze	350	437	385	682	315	367	455	665
			1B	cast steel	700	875	770	1365	630	735	910	1330
		50	1A	cast iron, bronze	472	577	525	910	350	402	490	717
			1B	cast steel	945	1155	1050	1820	700	805	980	1435
		65	1A	cast iron, bronze	595	735	647	1155	385	420	525	770
			1B	cast steel	1190	1470	1295	2310	770	840	1050	1540
		80	1A	cast iron, bronze	717	875	787	1382	402	455	560	822
			1B	cast steel	1435	1750	1575	2765	805	910	1120	1645
		100	1A	cast iron, bronze	945	1172	1050	1837	437	507	612	910
			1B	cast steel	1890	2345	2100	3675	875	1015	1225	1820
		125	1A	cast iron, bronze	1120	1382	1242	2170	525	665	735	1067
			1B	cast steel	2240	2765	2485	4340	1050	1330	1470	2135
	150	1A	cast iron, bronze	1417	1750	1575	2747	612	717	875	1277	
		1B	cast steel	2835	3500	3150	5495	1225	1435	1750	2555	
	pump port in horizontal "x" axis	50	1A	cast iron, bronze	525	472	577	910	350	402	490	717
			1B	cast steel	1050	945	1155	1820	700	805	980	1435
		65	1A	cast iron, bronze	647	595	735	1155	385	420	525	770
			1B	cast steel	1295	1190	1470	2310	770	840	1050	1540
		80	1A	cast iron, bronze	787	717	875	1382	402	455	560	822
			1B	cast steel	1575	1435	1750	2765	805	910	1120	1645
		100	1A	cast iron, bronze	1050	945	1172	1837	437	507	612	910
			1B	cast steel	2100	1890	2345	3675	875	1015	1225	1820
		125	1A	cast iron, bronze	1242	1120	1382	2170	525	665	735	1067
			1B	cast steel	2485	2240	2765	4340	1050	1330	1470	2135
		150	1A	cast iron, bronze	1575	1417	1750	2747	1612	717	875	1277
			1B	cast steel	3150	2835	3500	5495	1225	1435	1750	2555
200		1A	cast iron, bronze	2100	1890	2345	3657	805	927	1137	1680	
		1B	cast steel	4200	3780	4690	7315	1610	1855	2275	3360	

^b - ΣF and ΣM are vector totals of forces and moments.

If not all actual loads reach permissible maximum values, one of the loads may exceed permissible value, when an additional condition is met:

- no force or moment exceeds 1.4 x permissible value from table 5
- actual force and moment exerted on each port meets the following equation:

$$\left(\frac{\sum F_{rzeczywiste}}{\sum F_{dopuszcz}} \right)^2 + \left(\frac{\sum M_{rzeczywiste}}{\sum M_{dopuszcz}} \right)^2 \leq 2$$

The effect of material and temperature on permissible values of forces and moments.

Table 6

Material type	Temperature °C					
	20	60	100	140	180	220
	Correction factor 'K'					
Grey iron	1	0.983	0.968	0.952	0.929	0.904
Alloy steel 18-8	1	0.990	0.987	0.974	0.964	0.953
Carbon steel	1	0.990	0.980	0.971	0.961	0.952

All force and moment data included in table 5 are specified for 20°C. For other temperatures, data must be corrected in accordance with:

$$F_t = K \times F [N]$$

$$M_t = K \times M [Nm]$$

4.3. Electrical installation



The electrical installation should be performed by an authorised electrician and should conform to the local - requirements.

- The voltage supply should be as indicated on the motor data plate. During installation follow the instruction specified in the Technical Documentation of the motor.
- The motor should be protected by a thermo-bimetal relay, which is set at the nominal current value, specified on data plate of the motor.



Use electrical devices designed for use in explosion hazard areas.

CAUTION!

Remember to connect the pump to the earth.



Incorrect connection may cause motor damage.

Faulty electrical connection may lead to threat to life or health and to the damage of the motor. Make sure that the supply network allows to transit the starting current ($5x \div 7x$) higher than the rated current. If such possibility is not available, the user should try the soft-start or λ/Δ

- After electrical connection, check if the sense of rotation is consistent with arrows on the pump housing and/or on the motor fan cover.
- The sense of rotation can be checked by a short motor start.



It is not permitted to run the pump without liquid (dry).

CAUTION!

With wrong sense of rotational, will the pump not reach proper working parameters (Q and H). Risk of pump unit damage.

4.4. Safety requirements for installation and assembly

User must make sure all the installation and inspection works are carried out by an authorized and qualified personnel. Make sure the personnel is familiar with this manual. All operations are carried out when the unit is not in operation.

The pump units for hazardous products are subject to neutralization.

When all operations are completed, all safety devices shall be reinstalled and activated in accordance with the procedure.

5. ACCEPTANCE OF START - UP, OPERATION AND SHUTDOWN PROCEDURES,

5.1. Operational requirements

CAUTION!

It is essential to meet the following conditions. Damages resulting from non-observance of the conditions are not covered by the warranty. Pump unit may not be used for pumping media affecting the corrosion resistance of materials used for its construction.

- Each time the pump unit is restarted, verify if the pump is filled with liquid, and in case it is empty, fill it up.



In no case run the pump without liquid, even for a short period.

- For pump unit operating with suction (fig. 1), suction line shall be equipped with non-return valve and a strainer. Intense reversal of a liquid stream at pump shutdown may lead to liquid drain, rendering the suction impossible. Fill up the pump and suction line with liquid. Open pressure valve.
- For pumps operating with inflow (fig. 2) it is recommended that the pump inlet port is equipped with a gate valve at the suction side, which will be open during pump operation. Prime pump with liquid. Open pressure valve.



Gate valve (at the suction side) may not be used to adjust parameters of pump unit operation.

CAUTION!

Before first start, fill up the pump and the seal chamber with the handled liquid.

CAUTION!

Never start the pump with the pressure pipe slide closed. The rotating direction must be consistent with the arrow on the pump housing. When working with deep suction, before starting the pump, should the valve at the pressure outlet be throttled until suction occurs. Next adjust the valve to the required efficiency.

CAUTION!

Before leaving the factory, pump units are filled with an inhibitor, readily soluble in water. Do not use water from the first 5 minutes of initial pumping for food purposes



The pump shall not work without flow of liquid longer than 1 min. For a continuous running pump shall the minimal flow not be smaller than 10% of the full pump output.

5.2. Operation

CAUTION!

Pumps equipped with mechanical seal need no service. Leakage evidences seal damage, which should be replaced immediately.



Leakages of hazardous liquids should be drained off to avoid its dangerous effects for people and environment. The appropriate legal requirements should be observed.

Mounting new mechanical seals make sure to install rubber washers in the chamber and in the sliding ring. When mounting the mechanical seal onto the shaft it is recommended to moisten the shaft with water. If the shaft shoulder has a sharp edge, an auxiliary directing sleeve "1" (see Fig. 5) should be used, in order to avoid damage of the O-ring "2". Faces of sealing rings must be clean and free from cracks and scratches.

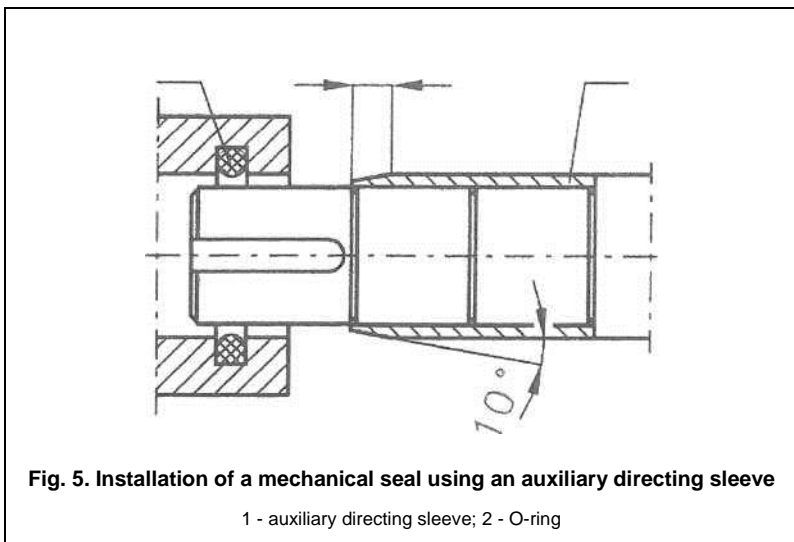

Pumps with gland packing demand regardful regulation.

- Before the first start, must the nuts for tightening the packing be turned only manually, without excessive force. **Do not overstrain the packing!**

CAUTION!

The start-up period of a new pump has a significant influence on the gland packing service-life. It is recommended to allow at the beginning something-greater leakage, and slowly reduce them in the course of time. The more leakage, the longer service life. During the first 15 min of work do not adjust the packing gland, even if the outflow is high. After some time adjust the packing gland stepwise and gently, to obtain a small drop outflow.

CAUTION!

A full stoppage of the outflow would cause the stuffing to wear out and an excessive shaft wearing.

When replacing the stuffing, take care not to scratch the shaft. The stuffing sections should be arranged as presented on Fig. 6.

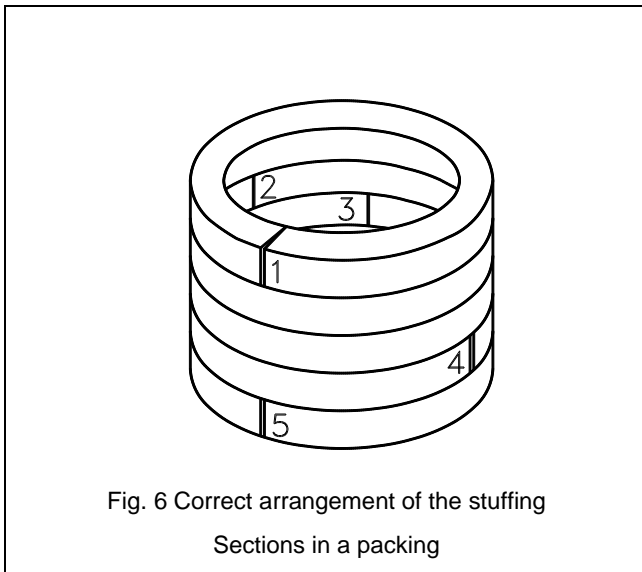

5.3. Shut-down

Make sure the liquid will not freeze; if there is a possibility of freezing, remove the liquid from the pump and the system.

6. SERVICE AND MAINTENANCE

No special maintenance is required for pump unit operation. Keep the pump and its vicinity clean. In case of negative temperature, drain water from pump and lines.

Sealed bearings are lubricated and does not require maintenance. Replace lubricant after the first 500 hours of operation, and then every 8000 hours of operation. Use ISO V6 100 oil (0.7 litre). Remove drain plug (47) and drain the oil. Make sure the chamber is empty, install drain plug, remove filler plug (46) and fill with oil (0.7 litre). Make sure the oil can be seen in a level sight glass (48).

CAUTION!

Mechanical seals does not demand maintenance. It shall in no case work dry, even for a short time.

For screw joints, do not exceed permissible torques specified in table 7. Most of the threaded joints are secured with Loctite adhesive. Before removing threaded joints it is recommended to heat it with hot air (temp. 200°C).

Torques of threaded connections

Table 7

Dimension		M6	M8	M10	M12	M16	M20
Tightening torque	Nm	9,3	23	45	77	125	190

Do not use excessive loads, especially dynamic loads when installing.

6.1. Spare part replacement

CAUTION!

The frequency of replacing spare parts depends in a high degree on the pump operating conditions. Therefore are the values given below only approximate values. Taking under consideration the complex structure of the whole pump assembly, the information in the table concern only to the following elements: the pump and motor bearings, mechanical packing and the motor winding.

Table 8

Wearing part		Mechanical seal	Motor bearings Pump bearings	Motor winding
Durability		10 000 h to 20 000 h	15 000 h to 30 000 h	20 000 h for outside temperature up to 40°C
Replacing frequency according to the working load	Continuous work	1-2 years	2-3 years	3 years
	15 h/day 9 months/year	2-5 years	4-8 years	6 years

7. TROUBLESHOOTING.

Dismounting the pump within the warranty period without manufacturer's permission will void the warranty.

CAUTION!

Before starting repairs turn the pump off.

Table 9

Trouble	Cause	Remedy
Pump unit rotates, but does not pump liquid.	<ul style="list-style-type: none"> a) water level below strainer b) pump not filled with liquid (non-return valve not tight, pump not degassed and not primed) c) valve between tank and pump is closed d) suction line is not tight e) soiled strainer f) pump unit is internally damaged g) pump shaft leaking h) speed too low or calculation error i) excessive suction head for specific pump unit 	<ul style="list-style-type: none"> a) verify water level and/or lower strainer b) check non-return valve, vent and prime pump c) verify if pump is open d) check suction line, pipe and connection tightness e) clean strainer f) disassemble and repair pump unit g) replace mechanical seal h) verify speed and calculations i) contact manufacturer
Overloaded motor (overheating)	<ul style="list-style-type: none"> a) voltage too low b) liquid density or viscosity higher than anticipated c) excessive mechanical loss due to wear 	<ul style="list-style-type: none"> a) check terminal voltage may not differ from nominal by +5% - 10% b) verify pump selection c) disassemble and repair pump unit

Trouble	Cause	Remedy
Delivery and pressure too low	<ul style="list-style-type: none"> a) Suction and pressure line diameter too small b) Incorrect sense of rotation c) Impeller rings worn d) Air bubbles in suction and pressure line e) Pressure line gate valve jammed f) Automatic pressure line gate valve closing g) Impeller ducts clogged h) Speed too low due to voltage drop or incorrect frequency i) Error in delivery head calculations 	<ul style="list-style-type: none"> a) Verify pump selection b) Modify sense of rotation by switching two phase wires c) Replace rings d) Verify suction line tightness and liquid level e) Excessive gate valve play, verify play f) Excessive gate valve play, verify play g) Clean the impeller, verify operation conditions h) Check frequency and supply voltage i) Verify calculations
Unit vibrations and water hammers	<ul style="list-style-type: none"> a) Pump delivery exceeds specified in the order b) Worn bearings and races c) Foreign bodies inside impeller ducts d) Impeller worn or damaged e) Improper sense of rotation 	<ul style="list-style-type: none"> a) Verify pump selection b) Replace bearings and races c) Clean the impeller, verify operation conditions d) Inadmissible operation conditions, replace impeller e) Modify sense of rotation by switching two phase wires

8. DOCUMENTATION.

Documentation is prepared according to the agreements made between the manufacturer and the client. "Technical Data", "User's Manual" and "Warrant Card" are always attached

9. GUIDELINES AND INSTRUCTIONS FOR USE IN EXPLOSION HAZARD AREAS.

9.1. Inspection schedule - pumps and couplings for use in explosion hazard areas.



Table 10

Explosion protection	<i>inspections</i>
II2GcIIBT4-T3	<ol style="list-style-type: none"> 1. Check circumferential clearance of flexible insert after 2000 hours of operation. Or every 4 months. 2. If no wear of flexible insert is visible, next inspection after 4000 hours of operation. Or every 12 months. 3. For substantial wear of flexible insert, find what is a cause of wear and replace the insert. 4. Replace bearing as per lower values specified in Table 8. 5. Replace end-face seals as per lower values specified in Table 8.

9.2. Coupling wear data



Check clearance between hub centre and flexible insert with feeler gauge. If permissible wear is exceeded, replace the insert irrespective of maintenance schedule.



Correct shaft alignment ensures long service life and safe operation.

EZ coupling size	Permissible wear Δ_{max} [mm]
1	1.5
3	2
7	2
9	3
10	3

9.3. Coupling materials for explosion hazard areas.

For explosion protection MB, the following materials of coupling hub are acceptable:

EN-GJ5-400-15-(GGG40) - ductile iron, alloy steel, carbon steel

CAUTION!

Coupling hubs made of light metal alloys e.g. aluminium are not acceptable.

9.4. Start-up



Check the following before pump unit start-up: tightening of Y/ coupling hub screws, concentricity of pump and motor shafts.

CAUTION!

Provide protection against contact with coupling.



Coupling protection in explosion hazard areas.
Protect the coupling against failing objects with guards

CAUTION!

The distance between the guard and a coupling must be at least 5 mm
Guards can be removed after the unit is completely stopped.



In case of problems:
stop the drive, find a cause, remedy a problem.

9.5. Leaks

Pump or pump unit for flammable, toxic, caustic or other hazardous liquids or liquids with temperature $> 60^{\circ}\text{C}$ shall be fitted with components, e.g. tubes for collecting and draining the product - leak from the gland or discharge from the pressure safety valve.

Protect the environment against the effect of leaks by fixed guards, screens and other safety devices.

9.6. Electrostatic discharge

Pump unit shall be protected with earth terminals against accumulation of positive charges. Earth terminal shall be directly connected with earth conductor. Pipe connections shall not be used as the earth conductors.



86-300 GRUDZIĄDZ/ Mniszek head office: 56/ **45 07 400**, fax 56/ **46 259 55**
ul. Droga Jeziorna 8 **46 236 23**

factory outlet: 56/ **45 07 310**, fax 56/ **46 264 16**
46 230 08

orders: 56/ **45 07 476**, fax 56/ **45 07 338**
46 211 41
46 226 29

Internet: www.hv.pl
E-mail: hv@hv.pl

Print: Studio Poligraficzne EUROPRINT s.c. 86-300 Grudziądz ul. Ikara 4 tel. (56) **46 46 750**